

# Tube Sheet Pro™ Grooving Tool

For grooving tube sheets in heat exchangers, condensers, and boilers with maximum productivity and professional results. Available from stock for four standard tube diameters: 5/8, 3/4, 7/8, and 1 inch. Designed for industry-standard double-groove configuration.

**INDUSTRY-  
STANDARD  
DOUBLE-GROOVE  
CONFIGURATION**

- High-quality tool with a proven design for grooving tube sheets of all standard materials.
- Smooth operation for accurate groove size and location, with good finishes.
- Easy to adjust for accuracy from the very first cut. Set-up instructions are marked on tool body for handy reference—no measurements are required.
- Easy cutter replacement—no disassembly required.
- Short tool stroke, with no exposed mechanism—no chip packing or “sticking.”
- TiN-coated high-speed steel cutters for long life.
- Pilots, specifically designed to maximize coolant flow for enhanced tool life, are interchangeable for easy diameter changes.
- Optional overtravel units available for use on CNC machines or other automated machinery, or when tube sheet is warped.



Interchangeable pilots allow easy diameter changes. Pilots are specifically designed to maximize coolant flow for enhanced tool life.



High-speed steel cutters are TiN-coated for long life.

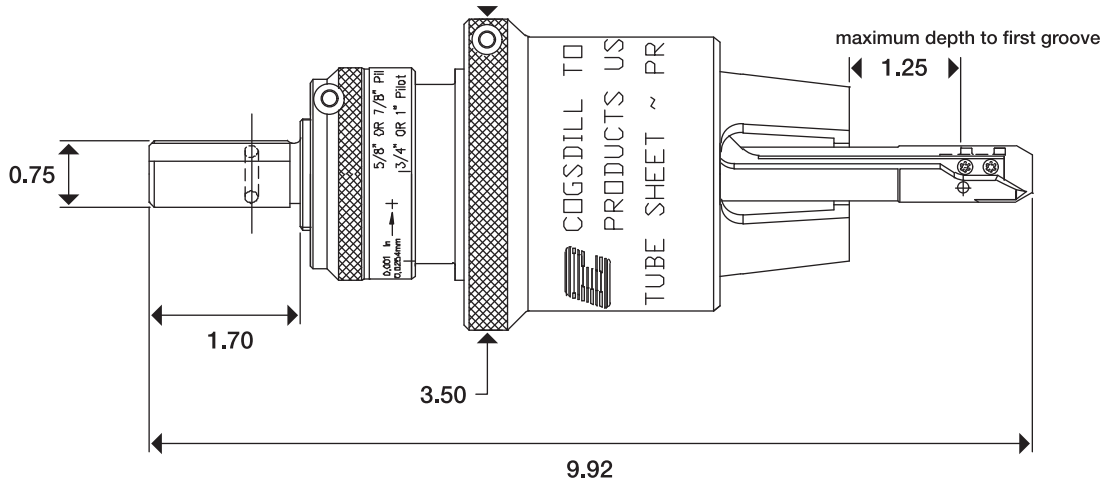

Note: Pilots made to fit TEMA standard tube sheet hole diameters.  
(See under "Pilot Only," below.)

Overtravel and morse taper shanks are available. (See below.)

### ■ COMPLETE TOOL ASSEMBLY

| Part number     | Description                                  |
|-----------------|--|
| ■ TSP-00625     | 5/8 in. complete tool with 3/4 in. SS        |
| ■ TSP-00750     | 3/4 in. complete tool with 3/4 in. SS        |
| ■ TSP-00875     | 7/8 in. complete tool with 3/4 in. SS        |
| ■ TSP-01000     | 1 in. complete tool with 3/4 in. SS          |
| ■ TSP-00625-3MT | 5/8 in. complete tool with #3MT              |
| ■ TSP-00750-3MT | 3/4 in. complete tool with #3MT              |
| ■ TSP-00875-3MT | 7/8 in. complete tool with #3MT              |
| ■ TSP-01000-3MT | 1 in. complete tool with #3MT                |
| ■ TSP-00625-1OT | 5/8 in. complete tool with 1 in. SS with OT* |
| ■ TSP-00750-1OT | 3/4 in. complete tool with 1 in. SS with OT* |
| ■ TSP-00875-1OT | 7/8 in. complete tool with 1 in. SS with OT* |
| ■ TSP-01000-1OT | 1 in. complete tool with 1 in. SS with OT*   |

### ■ HEAD ASSEMBLY ONLY

| Part number  | Description                                |
|--------------|--|
| ■ TSPH-3/4SS | Tube Sheet Pro head with 3/4 in. SS        |
| ■ TSPH-3MT   | Tube Sheet Pro head with #3MT              |
| ■ TSPH-1OT   | Tube Sheet Pro head with 1 in. SS with OT* |

\*OVERTRAVEL

### ■ ARM ONLY

| Part number | Description             |
|-------------|-------------------------|
| ■ TSP-02    | Small arm (5/8-3/4 in.) |
| ■ TSP-03    | Large arm (7/8 – 1 in.) |

### ■ PILOT ONLY

| Part number | Nominal Size (in.) | Actual Pilot Dia. (in.) |
|-------------|--------------------|-------------------------|
| ■ TSP-04    | 5/8 in. pilot      | .629                    |
| ■ TSP-05    | 3/4 in. pilot      | .754                    |
| ■ TSP-06    | 7/8 in. pilot      | .879                    |
| ■ TSP-07    | 1 in. pilot        | 1.006                   |

### ■ CUTTER ONLY

| Part number | Description   |
|-------------|---|
| ■ TTSP-08   | Standard cutter<br>2 x 1/8 in. grooves<br>(1/4 in. spacing) |
| ■ TSP-08A   | Optional cutter<br>2 x 1/8 in. grooves<br>(3/8 in. spacing) |

Refer to details drawing on next page.

### ■ MAKE SURE

- The cutter (**Detail #8**) is mounted in the arm (**D #2 or #3**) with two (**2**) #4-40 x 0.25" Torx screws (**D #9**).
- The pilot (**D #4, #5, #6, or #7**) and arm are installed at the same time.
- The pull yoke end of the arm (**opposite the cutter end of the arm**) is installed on the dowel (pull) pin (**D #34**) in the recessing head. The arm should be installed with the elevated platform contacting the leaf springs (**D #24**) in the head.
- Insert the pilot into the head, making sure the arm is mounted in the slot in the pilot. The pilot must be centered in the head and flush with the mounting face. The pilot is held into place with three (**3**) #10-24 x 5/8" cap screws (**D #38**).

### ■ DEPTH TO CUT (groove location)

- The stop (**D #25**) and housing (**D #23**) move together to adjust the tool to the desired depth to cut. This adjustment is made by loosening the locking screw (**D #30**) and screwing the housing/stop in or out. Do not force the housing; it should turn freely when the locking screw is backed off. Secure the position of the housing and the stop with the locking screw. The stop should rotate freely at all times.

### ■ DEPTH OF CUT (groove diameter)

- The depth of cut is controlled and adjusted by the adjusting collar (**D #21**). The adjusting collar is marked with details for setting the tool for standard tube sheet grooves. The adjusting collar is also marked so it can be adjusted in 0.001" increments. The locking screw must be loosened to adjust the adjusting collar. When the desired depth of cut is achieved, tighten the locking screw on the adjusting collar. If the machine holding the tool is controlling the depth of cut, back the adjusting collar off and secure it so it will not stop or restrict the tool. The adjusting collar must remain on the tool in order for the tool to operate correctly.



The adjusting collar is marked with details for setting the tool for standard tube sheet grooves. The adjusting collar is also marked so it can be adjusted in 0.001" increments.

### ■ MAKE SURE

- The tool must be centered over the hole to be grooved.
- Refer below for speeds and feeds.
- Coolant is strongly recommended for longer cutter life.
- With the tool rotating, feed the tool down until the pilot is in the hole and the nosepiece has come into contact with the surface of the part.
- At this time the cutter will begin to actuate.
- Feed the tool in until the cut is complete (the adjusting collar bottoms out).
- Feed the tool out at the same rate.

### ■ CUTTER CHANGE

- The cutter can be replaced in the tool without removal from the machine or disassembly. Remove the two (2) #4-40 x 0.25 Torx screws holding the cutter in place. Flush the cutter pocket in the arm to remove any chips or foreign material. Replace the cutter and secure with two (2) #4-40 x 0.25 Torx screws.

### ■ PILOT CHANGE

- The **Tube Sheet Pro** head accepts four standard pilots: 5/8", 3/4", 7/8", and 1". There are two (2) standard arms: one arm (D #2) is used with the 5/8" and 3/4" pilots, and one arm (D #3) is used with the 7/8" and 1" pilots. Remove three (3) #10-24 x 5/8" cap screws that retain the pilot. Pull the pilot from the head. If an arm change is not necessary, install the new pilot by the instructions in the set-up procedure.
- If an arm change is required, rotate the arm in the head until it releases from the dowel pin. Install the new arm and pilot, then secure with cap screws.

### ■ DISASSEMBLY

- Loosen the locking screw (D #30) and remove the housing (D #23) and nosepiece (D #25) by screwing the housing out. Remove three (3) #10-24 x 5/8" cap screws (D #38) retaining the pilot. Pull the pilot out of the head. The arm will pivot off of the dowel pin (D #34) as described above, and can be removed from the recessing head.
- Loosen the locking screw on the adjusting collar (D #21) and remove the collar, thrust race washer (D #31), and spring (D #32) from the tool. Remove the two (2) 3/8-24 x 5/16" flat point set screws (D #33). Remove the dowel pin from the sleeve. The spindle (D #20) will now slip out of the bottom and the tool will be completely disassembled.
- Reverse this sequence to assemble the tool.

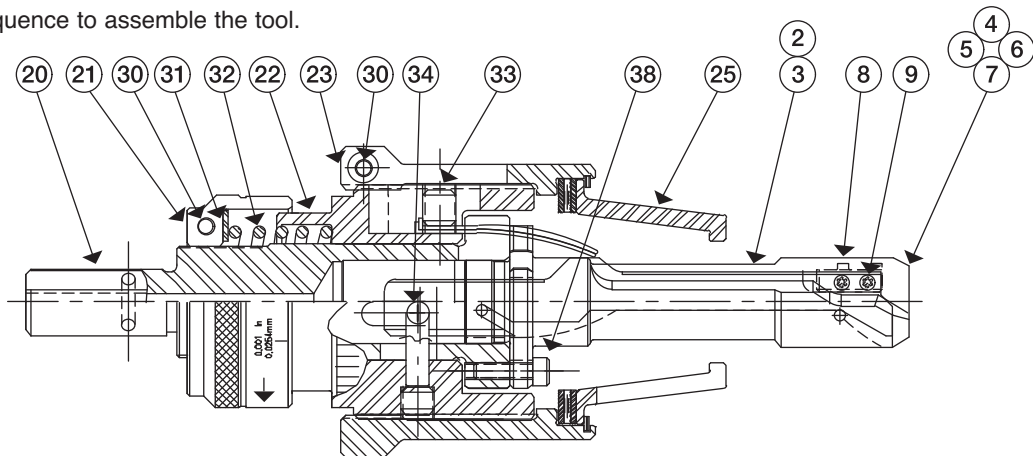

### ■ SUGGESTED OPERATING PARAMETERS

- 25 – 40 SFM
- 0.002 – 0.005 IPR (SPINDLE FEED RATE)